

Centrifugal fan type N35 with mounting feet / without mounting feet / with hose reel connection

standard handed RD 0° (other handings available) • protection degree IP 55 • efficiency class IE3

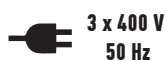
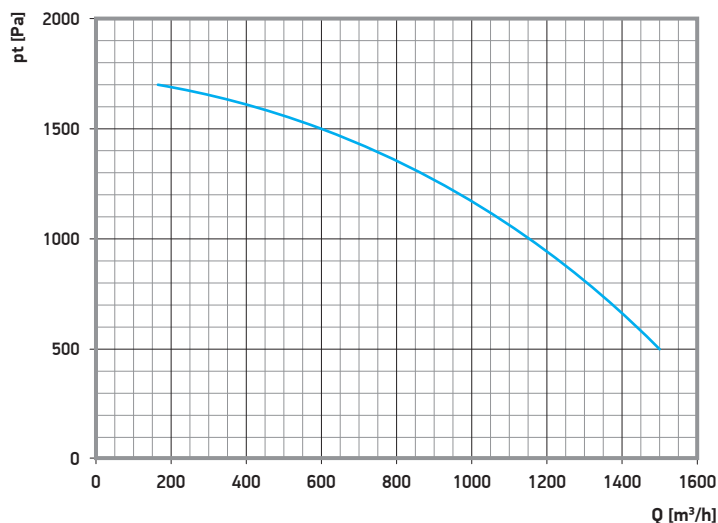
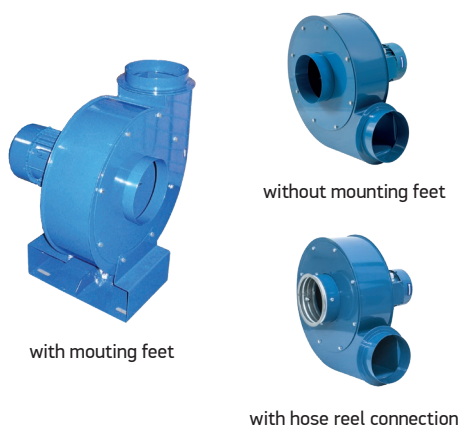

Catalogue number	Mounting feet	Air flow	Compression	Fan speed	Motor power	Current	Noise level	Weight
59-816-035	yes	180 - 1500 m³/h	1700 - 500 Pa	2790 rpm	0,75 kW	1,9 A	<79 dB (A)	20,0 kg
59-817-035	no	180 - 1500 m³/h	1700 - 500 Pa	2790 rpm	0,75 kW	1,9 A	<79 dB (A)	17,0 kg

55-4741-035 - with hose reel connection (technical data same as 59-817-035)

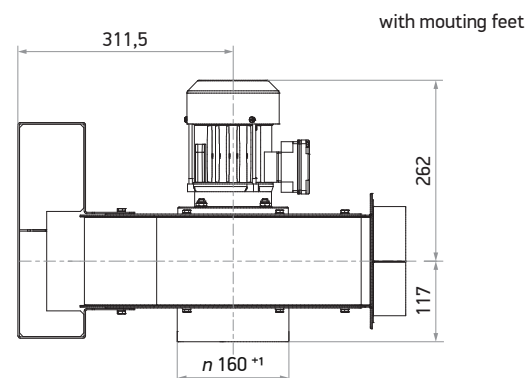
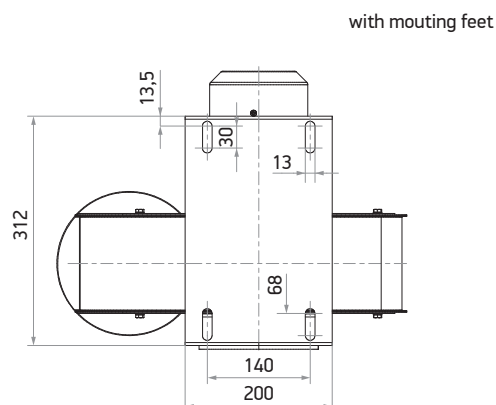
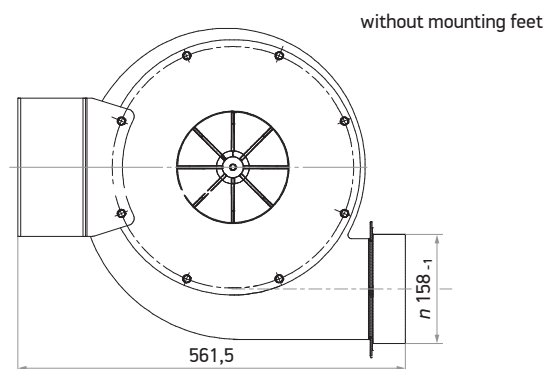
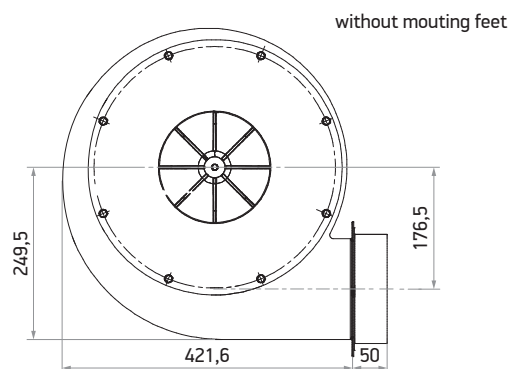

Vibration absorbers

- to avoid vibration transfer from fan to building structure
- including 4 vibration absorbers
- weight 0,2 kg

Cat. no.: 59-4864-016 Dimensions: 30 x 20 mm Thread: M8



Fan bracket kit

- 2 x brackets for mounting fans to walls and columns

Cat. no.: 80-4138-060 Length: 600 mm Weight: 12,0 kg



Anti vibration sleeve

- made of neoprene
- length 200 mm
- including 2 hose clips

Cat. no.: 59-4863-160 Diameter: 160 mm Weight: 0,8 kg
 59-4863-200 200 mm 0,9 kg



Motor protection switch

- can be used as an on/off switch
- weight 0,5 kg

Cat. no.: 74-5031-024 Power: up to 1,1 kW Current: 1,6 - 2,5 A



Repair switch

- to turn off the fan for maintenance purpose
- voltage 400 V
- current up to 25,0 A
- protection degree IP 65

Cat. no.: 73-031-007



Fan control for multiple remote switching

- fan starter for use with latching rotary switches
- cable ways for up to 3 remote switch points
- without motor protection

Cat. no.: 74-5100-000



Latching rotary switch

- for remote fan switching
- use with control panel cat. no. 74-5100-000
- weight 0,5 kg

Cat. no.: 74-5100-010



Acoustic enclosure box

- for working indoors
- made of steel
- sound absorption up to 12 dB(A)
- weight 67 kg

Cat. no.: 57-4890-171 Diameter: 160 mm



Acoustic enclosure box

- for changing weather conditions
- made of steel
- sound absorption up to 12 dB(A)
- weight 68 kg

Cat. no.: 57-4841-070 Diameter: 160 mm

