

Extraction rail ALU 150

self-sealing channel, vacuum

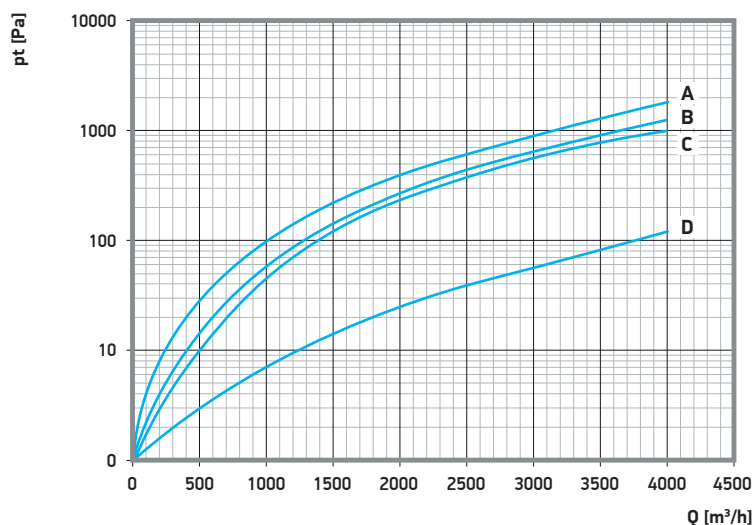
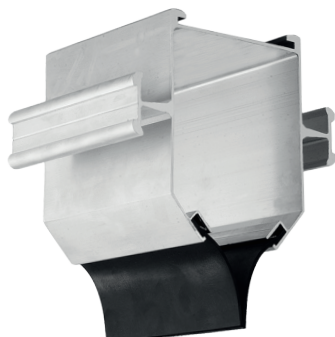

- A = duct connector top-long DN 250 mm
- B = duct connector top DN 250 mm
- C = duct connector end DN 250 mm
- D = extraction rail type ALU 150 / m

| Catalogue number | Rail selection | Sealing lip | | Operating temperature | Max distance between brackets | Weight |
|------------------|---------------------|-------------|----------|-----------------------|-------------------------------|---------|
| | | Material | Montage | | | |
| 10-4100-000 | 300 cm ² | EPDM | Fast | +150°C | 6 m | 12 kg/m |
| 10-4200-000 | 300 cm ² | Neopren | Standard | +150°C | 6 m | 12 kg/m |
| 10-4400-000 | 300 cm ² | Silicon | Standard | +200°C | 6 m | 12 kg/m |
| 10-4410-000 | 300 cm ² | Viton | Standard | +300°C | 6 m | 12 kg/m |

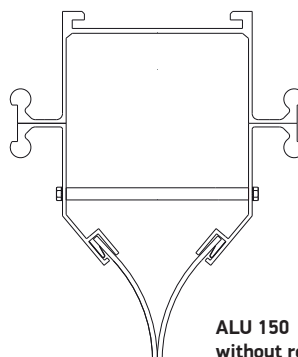
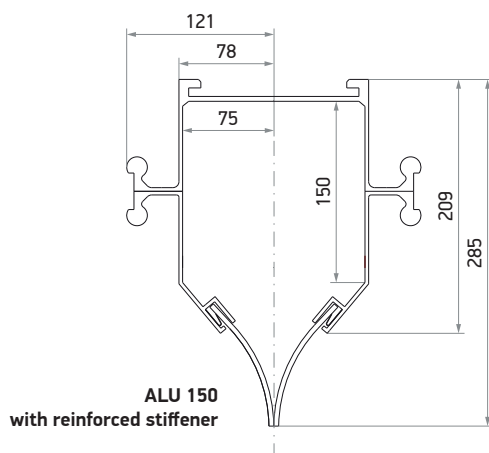

Extraction rail connector

- use every 5 m or 6 m
- made of steel
- mounting screws included
- weight 2,2 kg

Cat. no.:
12-4110-001



End cover

- made of aluminium
- mounting screws included
- weight 0,2 kg

Cat. no.:
12-4110-005



End stop

- mounted on both sides of the rail
- recommended 4 pcs. per rail
- weight 0,2 kg

Cat. no.:
12-4110-003



End stop with gas pressure spring

- made of steel
- weight 8,0 kg

Cat. no.:
12-4146-012



Rail brackets

- made of steel
- mounting screws included
- weight 0,7 kg

Cat. no.: 12-4110-002



Cat. no.: 12-4010-002



Through-bolt bracket

- made of steel

| Cat. no.: | Diameter: | Weight: |
|-------------|-----------|---------|
| 80-4133-003 | 300 mm | 1,3 kg |
| 80-4133-001 | 500 mm | 2,4 kg |



Duct connector (top)

- for the top of the extraction rail
- made of steel

| Cat. no.: | Diameter: | Height: | Weight: |
|-------------|-----------|---------|---------|
| 12-4120-160 | 160 mm | 180 mm | 1,6 kg |
| 12-4120-200 | 200 mm | 180 mm | 1,9 kg |
| 12-4120-250 | 250 mm | 180 mm | 2,5 kg |
| 12-4120-315 | 315 mm | 190 mm | 2,7 kg |



Duct connector (top-long)

- lenght 600 mm
- mounting screws included

| Cat. no.: | Diameter: | Lenght: | Weight: |
|-------------|-----------|---------|---------|
| 12-4124-160 | 160 mm | 270 mm | 2,1 kg |
| 12-4124-200 | 200 mm | 270 mm | 2,5 kg |
| 12-4124-250 | 250 mm | 300 mm | 3,9 kg |
| 12-4124-315 | 315 mm | 390 mm | 4,1 kg |



Duct connector (end)

- made of steel
- lenght 200 mm
- mounting screws included

| Cat. no.: | Diameter: | Weight: |
|-------------|-----------|---------|
| 12-4122-160 | 160 mm | 1,3 kg |
| 12-4122-200 | 200 mm | 1,4 kg |
| 12-4122-250 | 250 mm | 1,7 kg |

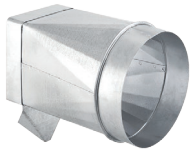

Rail stiffeners reinforced

- made of steel
- lenght 150 mm
- recommended 4 pcs. per rail with a length of 6 m

Cat. no.: 12-4110-021



Cat. no.: 12-4110-004



Rail for bowden cable operation

- activates the automatic disconnection function on the extraction trolley
- made of steel

Cat. no.:
12-4145-002



Rail coupler

- made of steel

Cat. no.:

12-4210-003 (ALU 150 / ALU 250)
12-4350-002 (ALU 150 / ALU 350)



Sealing lips* for standard mounting

- works with a spring strip (12-010-006)*
- dimensions 110 x 4,1 mm

| Cat. no.: | Lip: | Weight: |
|------------|---------|----------|
| 12-110-016 | Neopren | 0,7 kg/m |
| 12-401-006 | Silicon | 0,5 kg/m |
| 12-410-010 | Viton | 0,9 kg/m |

*extraction rail's standard equipment

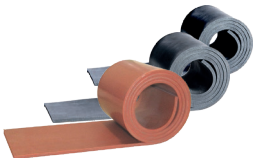

Sealing lips* for fast mounting

- made of EPDM
- dimensions 98 x 4 mm

Cat. no.:

13-010-007

*extraction rail's standard equipment

